

Flow Indicator ▪ Types SDM / SDMKR

B

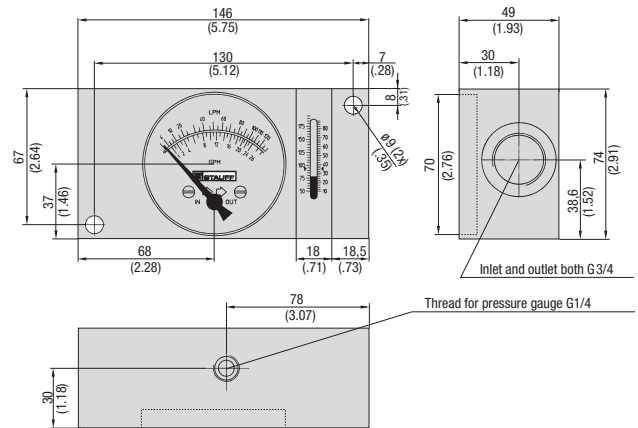

Dimensions SDM-750

Product Description

Analogue flow indicators for measuring the flow rate of fluids in mobile and industrial hydraulics. The SDMKR is designed with a loading valve for the strain test of the hydraulic system to facilitate precise control of the operating pressure. In addition, this product can also be subjected to a reverse flow direction (without flow rate determination).

Features

- Suitable for Mineral Oil (Aluminium), HFC Fluids and Water (Brass)
- Designed for in-line installation
- Mechanical flow measurement
- Controlling working pressure with a pressure control valve (only SDMKR)
- Flow indication in l/min and GPM for Aluminium units, Brass units have flow indication for Water and Oil both in l/min
- Aluminium unit: Dual scale
- Brass unit: Single scale
- Thread to connect with pressure gauge (only SDM)

Technical Data

Accuracy

(at a kinematic viscosity of 28cSt):

- Flow: ±4 % FSD
- Temperature: ±2,5 °C / ±5 °F
- Pressure (only SDMKR): ±1.6 % FS*
- Temp. measuring range: +20 °C ... +110 °C / +55 °F ... +245 °F
- Media temperature permanent: +80 °C / +176 °F
- temporary (<10 min.): +110 °C / +245 °F

Note: Other thread versions available on request.

Order Codes

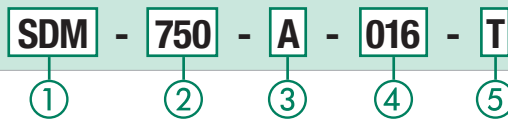

① Series and Type

Flow Indicator Type SDM	SDM
Flow Indicator Type SDMKR	SDMKR

② Size

750	750
1500 (only SDM)	1500

③ Housing Material

Aluminium	A
Brass (only SDM)	B

④ Flow Ranges

See table on page 63

⑤ Thermometer

With integrated thermometer (standard option) **T**

Functional Principal Flow Measuring

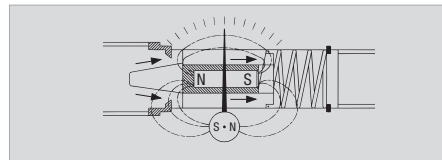

The flow indicators SDM and SDMKR have a sharp-edged orifice and a tapered metering piston, which moves in proportion to changes of flow against a spring. In no flow condition the piston closes the opening and the pointer indicates zero.

With increasing flow and differential pressure the piston moves against the calibrated spring. The piston movement is directly proportional to the flow rate and is magnetically coupled to the rotary pointer. During this function the sharp-edged orifice minimises the effects of viscosity. The flow is shown on a calibrated scale in l/min and gal/min.

Controlling Working Pressure with SDMKR

The pressure control valve of the SDMKR is directly connected to a flow-block and together with the integrated pressure gauge it allows an exact control of the working pressure in the maximum range.

For protection the SDMKR has two rupture disks. At a pressure >420 bar the disks burst and the fluid is by-passed around the valve. The rupture disks (other pressure ranges on request) can be replaced easily.

The SDMKR also permits flow in the reverse direction (without flow rate determination).



Flow Indicators ■ Types SDM / SDMKR

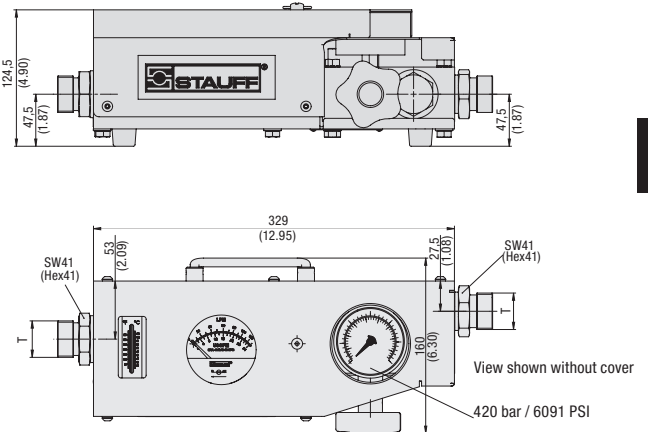
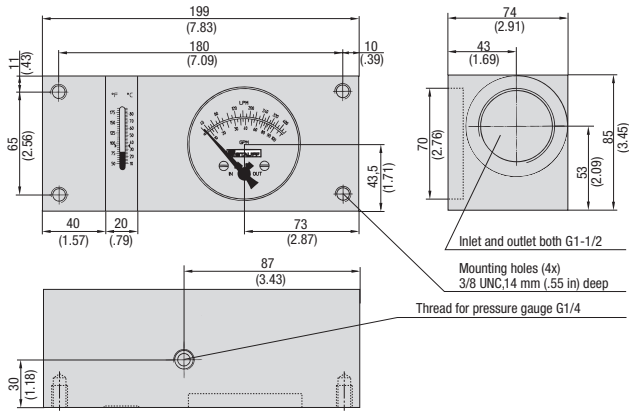

Technical Data

Max. Working Pressure (bar/PSI)	Flow Range (l/min / US GPM) Aluminum Units	Flow Range Brass Units (only SDM) *	Weight (kg/lbs)	Connection T	Order Codes
420	2 - 16	-	1,36	G3/4	SDM-750-A-016-T
6091	0.5 - 4	-	3.0	G3/4	SDM-750-A-030-T
420	2 - 30	-	1,36	G3/4	SDM-750-A-030-T
6091	0.5 - 8	-	3.0	G3/4	SDM-750-A-060-T
420	2 - 60	-	1,36	G3/4	SDM-750-A-060-T
6091	0.5 - 16	-	3.0	G3/4	SDM-750-A-120-T
420	4 - 120	-	1,36	G3/4	SDM-750-A-120-T
6091	1 - 32	-	3.0	G3/4	SDM-750-A-180-T
420	10 - 180	-	1,36	G3/4	SDM-750-A-180-T
6091	4 - 48	-	3.0	G3/4	SDM-750-B-030-T
420	-	2 - 30 l/min in oil	3,80	G3/4	SDM-750-B-030-T
6091	-	2 - 30 l/min in water	8.40	G3/4	SDM-750-B-060-T
420	-	3 - 60 l/min in oil	3,80	G3/4	SDM-750-B-060-T
6091	-	3 - 70 l/min in water	8.40	G3/4	SDM-750-B-120-T
420	-	4 - 120 l/min in oil	3,80	G3/4	SDM-750-B-120-T
6091	-	4 - 140 l/min in water	8.40	G3/4	SDM-1500-A-200-T
350	10 - 200	-	3,0	G1-1/2	SDM-1500-A-300-T
5075	5 - 50	-	6.61	G1-1/2	SDM-1500-A-300-T
350	20 - 300	-	3,0	G1-1/2	SDM-1500-A-400-T
5075	4 - 80	-	6.61	G1-1/2	SDM-1500-A-400-T
350	20 - 400	-	3,0	G1-1/2	SDM-1500-B-200-T
5075	5 - 100	-	6.61	G1-1/2	SDM-1500-B-200-T
350	-	10 - 200 l/min in oil	8,0	G1-1/2	SDM-1500-B-400-T
5075	-	10 - 200 l/min in water	17.64	G1-1/2	SDM-1500-B-400-T
350	-	20 - 400 l/min in oil	8,0	G1-1/2	SDMKR-750-A-030-T
5075	-	20 - 400 l/min in water	17.64	G1-1/2	SDMKR-750-A-030-T
420	2 - 30	-	6,6	G3/4	SDMKR-750-A-060-T
6091	0.5 - 8	-	14.55	G3/4	SDMKR-750-A-060-T
420	5 - 60	-	6,6	G3/4	SDMKR-750-A-120-T
6091	1.3 - 16	-	14.55	G3/4	SDMKR-750-A-120-T
420	5 - 120	-	6,6	G1	SDMKR-750-A-200-T
6091	1.3 - 32	-	14.55	G1	SDMKR-750-A-200-T
420	10 - 200	-	6,6	G1	SDMKR-750-A-200-T
6091	4 - 53	-	14.55	G1	SDMKR-750-A-200-T

Flow Curves - Aluminium Version (Oil)

(Curves refer to kinematic viscosity of 25cSt):

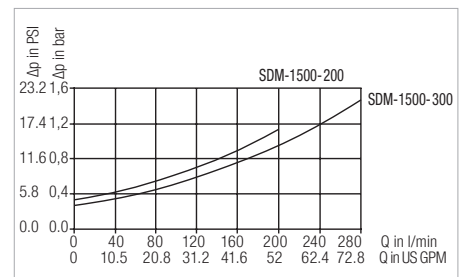
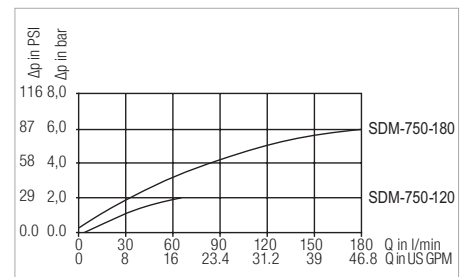
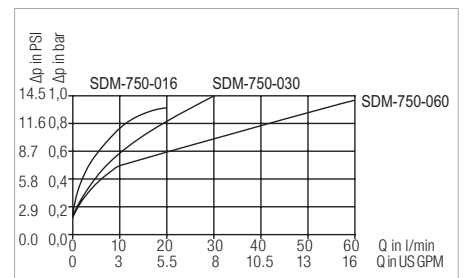

Flow Curves - Brass Version (Water)

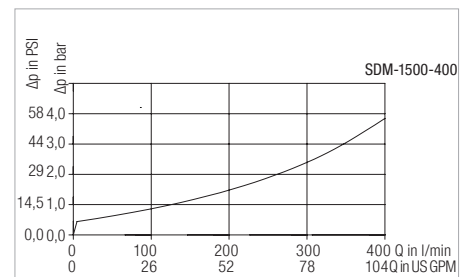
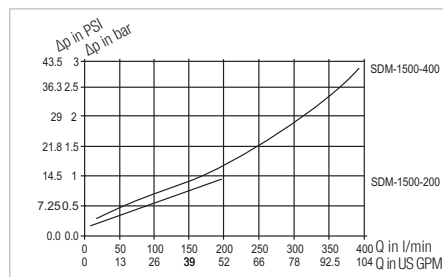
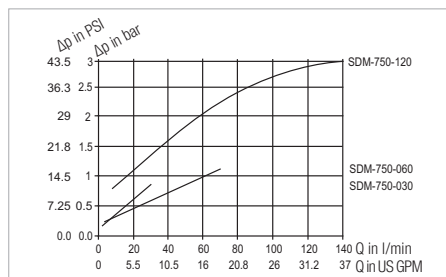

* The Brass units have a scale for water and oil – l/min.
Dimensional drawings: All dimensions in mm (in).

