



Pressure switch

KPS

Suitable for use in monitoring alarm and control systems in factories, diesel plants, compressors, power stations and on board ships.

Description

The KPS series consists of a series of pressure and temperature controlled switches. In this series, special attention has been given to meeting demands for a high level of enclosure, robust and compact construction, and resistance to shock and vibration.

For KPS pressure switches the position of the contacts depends on the pressure in the inlet connection and the set scale value.

For KPS thermostats the position of the contacts depends on the temperature of the sensor and the set scale value.

The series covers most outdoor as well as indoor application requirements and is suitable for use in monitoring alarm and control systems in factories, diesel plants, compressors, power stations and on board ships.

Features & benefits

- A high level of enclosure
- Adjustable differential
- Robust and compact construction
- Resistance to shock and vibration
- Available with all major marine approvals



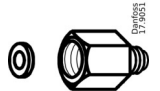


Ordering

Product code numbers

Type	Regulation range [bar] Pe [min]	Regulation range [bar] Pe [max]	Differential [bar]	Differential [bar] [min]	Differential [bar] [max]	Max. Working Pressure [bar]	Burst pressure [bar]	Pressure connection type	Pressure connection size	Code number
KPS31	0.00	2.50	0.10			6.0		G	1/4	060-315666
KPS31	0.00	2.50	0.10			6.0		G	1/4	060-311066
KPS31	0.00	2.50	0.10			6.0		G	3/8	060-310966
KPS31	0.00	2.50	0.10			6.0		G	1/4	060-410066
KPS33	0.00	3.50	0.20			10.0		G	1/4	060-310466
KPS33	0.00	3.50	0.20			10.0		G	3/8	060-311766
KPS33	0.00	3.50	0.20			10.0		G	3/8	060-310366
KPS33	0.00	3.50	0.20			10.0		G	3/8	060-314366
KPS35	0.00	8.00	0.40			12.0		G	1/4	060-318166
KPS35	0.00	8.00		0.40	1.50	12.0		G	1/4	060-310566
KPS35	0.00	8.00		0.40	1.50	12.0		G	3/8	060-410266
KPS35	0.00	8.00		0.40	1.50	12.0		G	1/4	060-411166
KPS35	0.00	8.00		0.40	1.50	12.0		G	1/4	060-318366
KPS35	0.00	8.00		0.40	1.50	12.0		G	3/8	060-310066
KPS35	0.00	8.00	0.50			12.0		G	1/4	060-318266
KPS35	0.00	8.00	0.40			12.0		G	1/4	060-318666
KPS35	0.00	8.00	0.40			12.0		G	1/4	060-310866
KPS35	0.00	8.00		0.40	1.50	12.0		G	3/8	060-314466
KPS37	6.00	18.00		0.85	2.50	22.0		G	1/4	060-310666
KPS37	6.00	18.00		0.85	2.50	22.0		G	3/8	060-310166
KPS39	10.00	35.00		2.00	6.00	45.0		G	3/8	060-310266
KPS39	10.00	35.00		2.00	6.00	45.0		G	3/8	060-419266
KPS39	10.00	35.00		2.00	6.00	45.0		G	1/4	060-410466
KPS39	10.00	35.00		2.00	6.00	45.0		G	1/4	060-310766
KPS39	10.00	35.00		2.00	6.00	45.0		G	3/8	060-319266
KPS43	1.00	10.00		0.70	2.80	120.0	240.0	G	1/4	060-410566
KPS43	1.00	10.00		0.70	2.80	120.0	240.0	G	1/4	060-312066
KPS43	1.00	10.00	2.00			120.0	240.0	G	1/4	060-411366
KPS45	4.00	40.00		2.20	11.00	120.0	240.0	G	1/4	060-312166
KPS45	4.00	40.00	5.00			120.0	240.0	G	1/4	060-411466
KPS45	4.00	40.00		2.20	11.00	120.0	240.0	G	1/4	060-410666
KPS47	6.00	60.00		3.50	17.00	120.0	240.0	G	1/4	060-312266

Accessories code numbers

Table: Accessories

Part	Figure	Description	Code number
Connector with nipple		G 3/8 connector, nipple and washer (10 mm o.d. × 6.5 mm i.d.) for brazing	017-436866
Connector with nipple		G 3/8 connector, nipple and washer (10 mm o.d. × 6.5 mm i.d.) for welding	017-422966
Reducer		G 3/8 × 7/16 – 20 UNF (1/4 flare) reduction with washer	017-420566
Adapter		G 3/8 × 1/8 – 27 NPT with washer	060-333466
Nipple		G 3/8 o.d × 7/16 – 20 UNF (1/4 flare)	060-324066

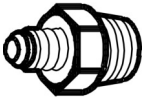




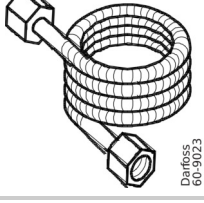
Nipple		G 3/8 A – 1/4 NPT with washer	060-333566
Adapter		G 3/8 x 1/4 – 18 NPT with washer	060-333666
Nipple		G 1/4 A x G 3/8 A	060-333266
		G 1/4 A x o.d. M10 x 1 with washer	060-333866
Damping coil	 Danfoss 60.9002	Damping coil with 1/4 flare connectors and 1 m copper capillary tube. Damp-ing coils used for applications with 3/8 RG connector requires the use of reduc-er. For information about capillary tube lengths, please contact Danfoss.	060-017166
Damping coil	 Danfoss 60.903C	Damping coil with G 3/8 connectors and 1.5 m copper capillary tube	060-104766
Armored damping coil	 Danfoss 60.9023	Damping coil with G 3/8 connectors and 1 m armored copper capillary tube. Standard washers included.	060-333366

Figure: Sensor pocket. Supplied without gland nut, gaskets and washer

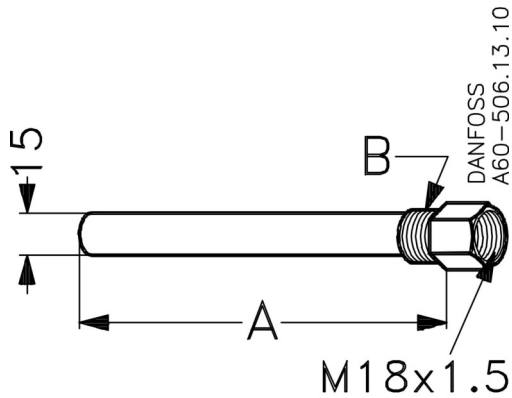


Table: Sensor pockets

Brass sensor pocket			Steel 18/8 sensor pocket		
A	B	Code number	A	B	Code number
[mm]	Thread		[mm]	Thread	
65	½ NPT	060L326566	-	-	-
75	½ NPT	060L326466	75	G ½ A	060L326766
75	G ½ A	060L326266	-	-	-
75	G ¾ A	060L326666	-	-	-
75	G ½ A	060L328166	-	-	-
110	½ NPT	060L328066	110	G ½ A	060L326866
110	G ½ A	060L327166	110	½ NPT	060L327066
110	G ½ A	-	-	-	-
110	G ¾ A	060L340366	-	-	-
160	G ½ A	060L326366	160	G ½ A	060L326966
200	G ½ A	060L320666	-	-	-
200	G ½ A	060L340866	-	-	-
250	G ½ A	060L325466	-	-	-
330	G ½ A	060L325566	-	-	-

Table: Accessories

Part	Figure	Description	Code no.
Clamping band		For KPS thermostats with remote sensor (L = 392 mm)	017-420466
W Heat-conductive compound (4.5 cm ² tube)		For KPS thermostats with sensor fitted in a sensor pocket. Compound for filling sensor pocket to improve heat transfer between pocket and sensor. Application range for compound: between pocket and sensor. Application range for compound: -20 – 150 °C, momentarily up to 220 °C.	041E0115
Gasket set		For KPS thermostats without armored capillary tubes	060L327366
Gasket set		For KPS thermostats with armored capillary tubes	060L036666

Overview

Product portfolio

Figure: Overview

Standard pressure switches

[bar]							Range P _e [bar]	Type
0	10	20	30	40	50	60		
█							0 – 3.5	CAS 133
█	█						0 – 10	CAS 136
	█	█	█	█			6 – 18	CAS 137
		█	█	█	█	█	10 – 35	CAS 139

Pressure switches for high pressure and strongly pulsating media

[bar]							Range P _e [bar]	Type
0	10	20	30	40	50	60		
█	█	█					1 – 10	CAS 143
	█	█	█	█	█	█	4 – 40	CAS 145
		█	█	█	█	█	6 – 60	CAS 147

Differential pressure switches

[bar]							Range P _e [bar]	Type
0	10	20	30	40	50	60		
█							0.2 – 2.5	CAS 155

Thermostats

[°C]								Range [°C]	Type
0	20	40	60	80	100	120	140		
	█	█	█	█	█	█	█	20 – 80	CAS 178
		█	█	█	█	█	█	70 – 120	CAS 180
			█	█	█	█	█	60 – 150	CAS 181

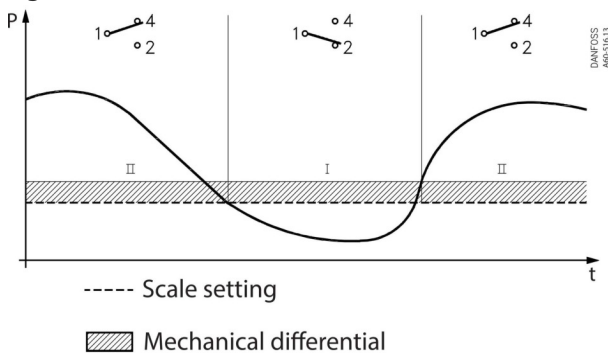
Functions

Pressure switch

KPS 31

Contacts 1-2 make and contacts 1-4 break when the pressure falls under the set range value. The contacts changeover to their initial position when the pressure again rises to the set range value plus the differential

Figure: KPS 31

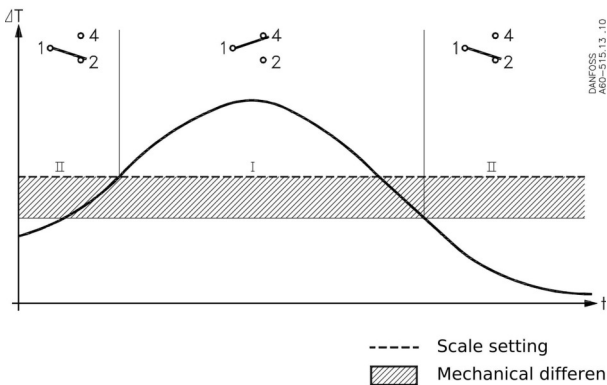


I	Alarm for falling pressure given at the set range value
II	Alarm for rising pressure given at the set range value plus the differential.

All other KPS pressure switches

Contacts 1-4 make and contacts 1-2 break when the pressure rises above the set range value. The contacts changeover to their initial position when the pressure again fails to the range value minus the differential

Figure: KPS pressure SWITCHES



I	Alarm for rising pressure given at the set range value
II	Alarm for falling pressure given at the set range value minus the differential

KPS 45

Example 1

An alarm must be given when the lubricating oil pressure in an engine fall below 0.8 bar. The alarm is in the form of a lamp. Choose a KPS 31 (range 0 – 2.5 bar). The minimum permissible lubricating oil pressure of 0.8 bar must be set on the range spindle. The differential is fixed at 0.1 bar, i.e. the alarm will not cut out before the pressure rises to 0.9 bar. The lamp must be connected to terminals 1 and 2 in the pressure switch.

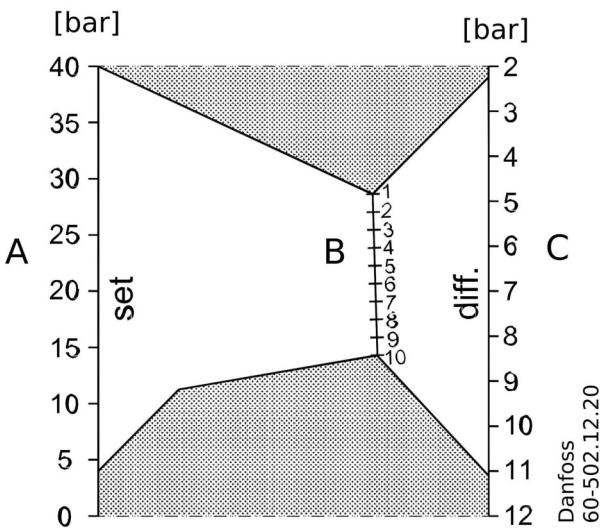
Example 2

An alarm must be given by a bell when the pressure in a boiler rises to 10 bar. The normal operating pressure is 9 bar. Choose a KPS 37 (range 6 – 18 bar). The range value of the pressure switch must be set at 10 bars, the differential at 1 bar. The bell must be connected to terminals 1 and 4.

Example 3

The pressure in a start air reservoir must be regulated with a compressor controlled by a KPS pressure switch so that it lies between 30 and 36 bar. Choose a KPS 45 (range 4 – 40 bar). The range value must be set at 36 bar. The differential of 6 bar must be set in accordance with the nomogram, , at approx. 2 on the differential scale. The required start function is obtained by connection to terminals 1 and 2 in the pressure switch.

Figure: KPS 45



Thermostat

Selection of differential

To ensure that the plant functions properly, a suitable differential is necessary. Too small a differential will give rise to short running periods with a risk of hunting. Too high a differential will result in large temperature variations.

Differentials

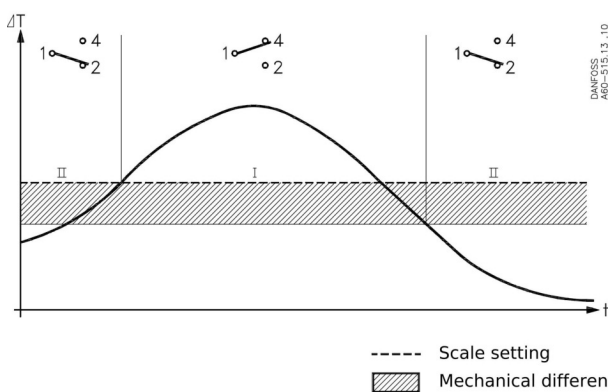
The mechanical differential is the differential that is set by the differential spindle in the temperature control. The thermal differential (operating differential) is the differential the system operates on. The thermal differential is always greater than the mechanical differential and depends on three factors:

1. the flow velocity of the medium,
2. the temperature change rate of the medium,
3. the heat transmission to the sensor.

Thermostat function

Contacts 1–4 make while contacts 1–2 break when the temperature rises above the scale setting. The contacts changeover to their initial position when the temperature falls to the scale setting minus the differential.

Figure: KPS pressure switches



I	Alarm for rising pressure given at the set range value
II	Alarm for falling pressure given at the set range value minus the differential

Product details

General data

Table: Technical Data

Switch	Single pole changeover (SPDT)	Contact material: Gold-plated silver contact	
Contact load (when Au surface is burnt away)	Alternating current	Ohmic	10 A, 440 V, AC-1
		Inductive	6 A, 440 V, AC-3
			4 A, 440 V, AC-15
		Starting current	max. 50 A (locked rotor)
Ambient temperature	KPS 31 – 39	-40 – 70 °C	
	KPS 43 – 47	-25 – 70 °C	
Temperature of medium (1)	KPS 31 – 39	-40 – 100 °C	
	KPS 43 – 47	-25 – 100 °C	
Vibration resistance	Vibration-stable in the range 2 – 30 Hz, amplitude 1.1 mm og 30 – 300 Hz, 4 g.		
Enclosure	IP67 (including IPX6) according to EN 60529. The pressure switch housing is enamelled pressure die cast aluminium (GD-ALSi 12). The cover is fastened by four screws which are anchored to prevent loss. The enclosure can be sealed with wire.		
Cable entry	Pg 13.5 for cable diameters from 5 – 14 mm.		
Identification	The type designation and code no. of the unit is stamped in the side of the housing.		

⁽¹⁾ For water and seawater, max. 80 °C.

Table: Types

Types	Scale accuracy	Mean value of snap point variation after 400 000 operations
	[bar]	[bar]
KPS 31	±0.2	±0.1
KPS 33	±0.3	±0.2
KPS 35	±0.5	±0.3
KPS 37	±1.0	±0.4
KPS 39	±3.0	±0.7
KPS 43	±1.0	±0.2
KPS 45	±4.0	±1.0
KPS 47	±6.0	±1.5

Table: Materials in contact with the medium

Type	Materials	
KPS 31, KPS 33	Bellows capsule	Deep-drawn plate, material no. 1.0524 (DIN 1624)
	Bellows	Stainless steel, material no. 1.4306 (DIN 17440)
	Pressure connection	Steel C20, material no. 1.0420 (DIN 1652)
KPS 35, KPS 37, KPS 39	Bellows	Stainless steel, material no. 1.4306 (DIN 17440)
	Pressure connection	Brass, W. no. 2.0401 (DIN 17660)
KPS 43, KPS 45, KPS 47	Diaphragm capsule	Nickel-plated brass, DIN 50 968 Cu/Ni 5 (DIN 1756)
	Diaphragm	Nitrile-Butadien rubber

Figure: KPS 43

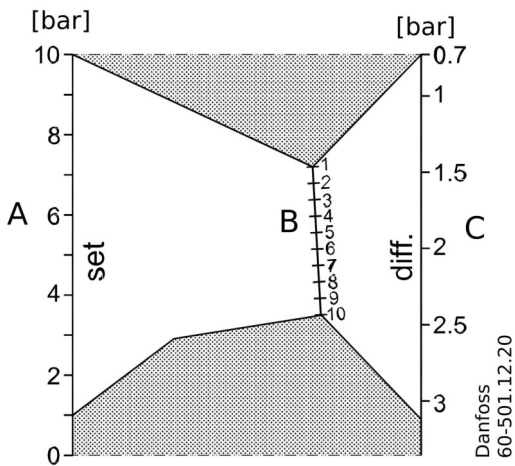


Figure: KPS 45

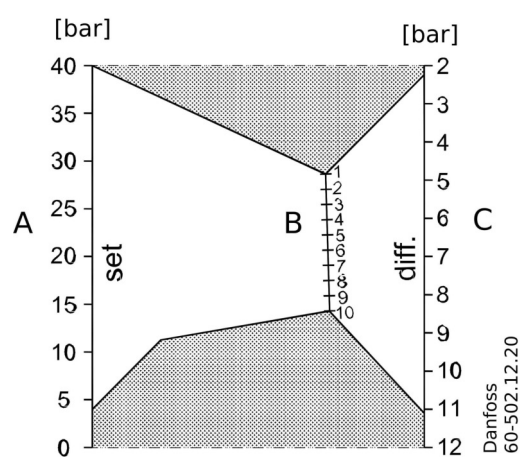
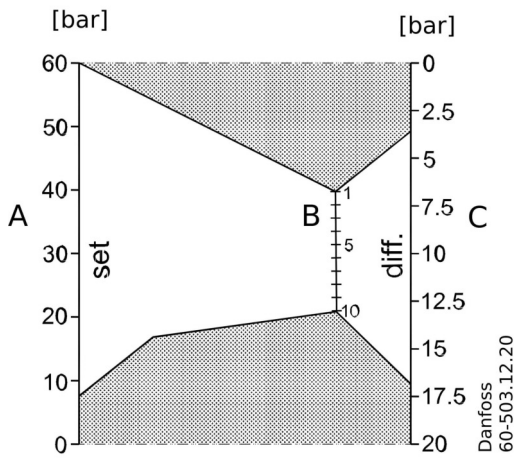
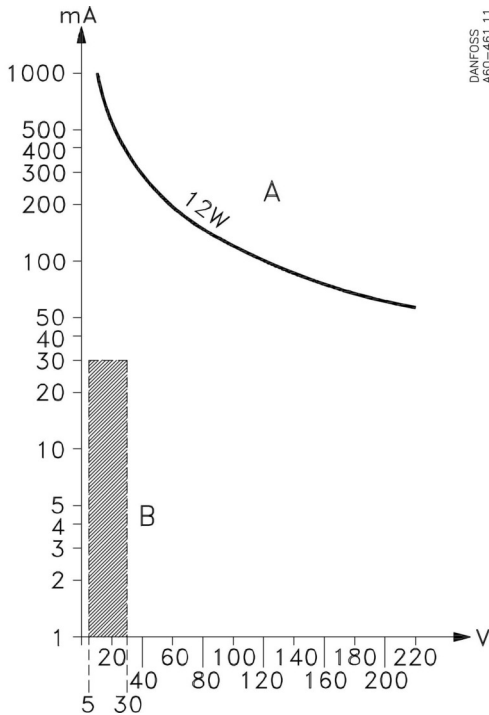


Figure: KPS 47



A	Range setting
B	Differential scale
C	Obtained differential

Figure: Direct current (DC) -load



DANFOSS
A60-461.11

Curve A	gives the maximum load
Hatched area B	Acceptable load for the gold plating of the contact

Terminology

Range setting

The pressure range within which the unit will give a signal (contact changeover).

Differential

The difference between make pressure and brake pressure

Permissible overpressure

The highest permanent or recurring pressure the unit can be loaded with.

Max. test pressure

The highest pressure the unit may be subjected to when, for example, testing the system for leakage. Therefore, this pressure must not occur as a recurring system pressure.

Min. bursting pressure

The pressure which the pressure-sensitive element will withstand without leaking.

Thermostat

Table: Technical data

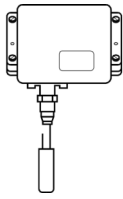
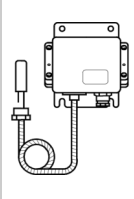
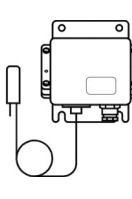
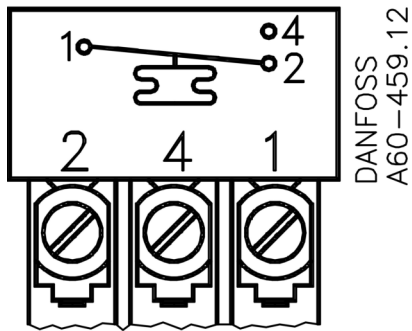
Type	Setting range Pe	Mech. diff. adjustable/ fixed	Max. sensor temperature	Suitable sensor pocket [mm]				Cap. tube length	Code number		
	[°C]	[°C]	[°C]					[m]			
KPS 76	-10 – 30	3 – 10	80	65	75	110	160	2	–	060L311266	060L311366
KPS 77	20 – 60	3 – 14	130	–	75	–	–	–	060L311866	–	–
KPS 77	20 – 60	3 – 14	130	–	–	110	–	–	060L310066	–	–
KPS 77	20 – 60	3 – 14	130	–	–	–	160	–	060L313666	–	–
KPS 77	20 – 60	3 – 14	130	65	75	110	160	2	–	060L310166	060L310266
KPS 77	20 – 60	3 – 14	130	–	–	110	160	5	–	060L311966	–
KPS 79	50 – 100	4 – 16	200	–	75	–	–	–	060L312166	–	–
KPS 79	50 – 100	4 – 16	200	–	–	110	–	–	060L310366	–	–
KPS 79	50 – 100	4 – 16	200	–	–	–	160	–	060L313766	–	–
KPS 79	50 – 100	4 – 16	200	65	75	110	160	2	–	060L310466	060L310566
KPS 79	50 – 100	4 – 16	200	–	–	110	160	5	–	060L312266	–
KPS 79	50 – 100	4 – 16	200	–	–	110	160	8	–	060L312466	–
KPS 79	50 – 100	4 – 16	200	65	75	110	160	3	–	060L314366	–
KPS 80	70 – 120	4.5 – 18	220	–	75	–	–	–	060L312666	–	–
KPS 80	70 – 120	4.5 – 18	220	–	–	110	–	–	060L312766	–	–
KPS 80	70 – 120	4.5 – 18	220	–	–	–	160	–	060L313866	–	–
KPS 80	70 – 120	4.5 – 18	220	–	–	–	200	–	060L315766	–	–
KPS 80	70 – 120	4.5 – 18	220	65	75	110	160	2	–	060L312866	060L312966
KPS 80	70 – 120	4.5 – 18	220	65	75	110	160	3	–	060L315666	–
KPS 80	70 – 120	4.5 – 18	220	–	–	110	160	5	–	060L313066	–
KPS 80	70 – 120	4.5 – 18	220	–	–	110	160	8	–	060L313266	–
KPS 81	60 – 150	5 – 25	250	65	75	110	160	2	–	060L310666	060L310766
KPS 81	60 – 150	5 – 25	250	–	–	110	160	5	–	060L313466	–
KPS 81	60 – 150	5 – 25	250	–	–	110	160	8	–	060L311166	–
KPS 81	60 – 150	5 – 25	250	–	–	200	–	–	060L311066	–	–
KPS 83	100 – 200	6.5 – 30	300	65	75	110	160	2	–	060L310866	060L310966
KPS 83	100 – 200	18	300	65	75	110	160	2	–	060L313966	–

Figure: Electrical connection

KPS thermostats are fitted with a screwed cable entry suitable for cables from 5 – 14 mm.

Table: Technical data

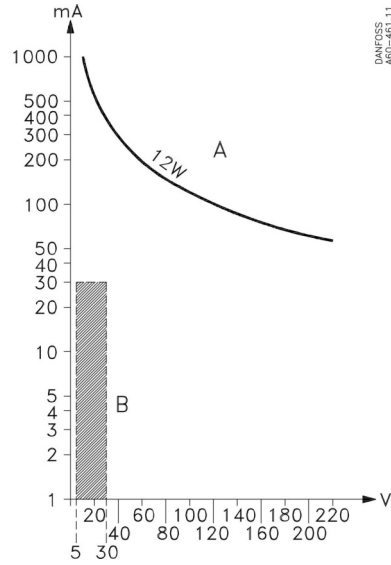
Switch	Single pole changeover (SPDT)	Contact material: Gold-plated silver contact	
Contact load (when Au surface is burnt away)	Alternating current	Ohmic	10 A, 440 V, AC-1
		Inductive	6 A, 440 V, AC-3
			4 A, 440 V, AC-15
		Starting current	max. 50 A (locked rotor)
	Direct current	12 W, 220 V, DC-13	
Ambient temperature	-40 – 70 °C		
Vibration resistance	Vibration-stable in the range 2 – 30 Hz, amplitude 1.1 mm og 30 – 300 Hz, 4 G.		
Enclosure	IP67 to EN 60529 / IEC 60529. The thermostat housing is enamelled pressure die cast aluminium (GID-AISI 12). The cover is fastened by four screws which are anchored to prevent loss. The enclosure can be sealed with fuse wire.		
Cable entry	Cable diameters from 5 – 14 mm.		
Identification	The type designation and code no. of the unit is stamped in the side of the housing.		

Table: Types

Types	Scale accuracy (1)	Snap point variation after 400 000 operations
	[°C]	[°C]
KPS 76	±3	max. drift 2
KPS 77	±3	max. drift 2
KPS 79	±3	max. drift 2
KPS 80	±3	max. drift 2
KPS 81	±6	max. drift 2
KPS 83	±6	max. drift 2

⁽¹⁾ Scale values are indicative only. Results given in table are measured in laboratory conditions for factory set values (scale center). The scale accuracy for min and max positions could differ significantly. There are many factors which could influence on product working and scale accuracy.

Figure: Direct current (DC) -load



Curve A	gives the maximum load
Hatched area B	Acceptable load for the gold plating of the contact

Pressure and temperature data

Table: Pressure switches

Type	Setting range P_e	Adjustable/ fixed differential	Permissible operating pressure P_e	Max. test pressure	Pressure connection	Code number
	[bar]	[bar]	[bar]	[bar]		
KPS 31	0 – 2.5	0.1	6	6	G ¼	060-311066
KPS 31	0 – 2.5	0.1	6	6	G ¾ A	060-310966
KPS 33	0 – 3.5	0.2	10	10	G ¼	060-310466
KPS 33	0 – 3.5	0.2	10	10	G ¾ A	060-310366
KPS 35	0 – 8	0.4 – 1.5	12	12	G ¼	060-310566
KPS 35	0 – 8	0.4 – 1.5	12	12	G ¾ A	060-310066
KPS 35	0 – 8	0.4	12	12	G ¼	060-310866
KPS 37	6 – 18	0.85 – 2.5	22	27	G ¼	060-310666
KPS 37	6 – 18	0.85 – 2.5	22	27	G ¾ A	060-310166
KPS 39	10 – 35	2.0 – 6	45	53	G ¼	060-310766
KPS 39	10 – 35	2.0 – 6	45	53	G ¾ A	060-310266

Figure: KPS 31, KPS 33



Figure: KPS 35, 37, 39



Table: Pressure switches for high pressure and strongly pulsating media

Type	Setting range Pe	Adjustable diff. see Figure: KPS 43 , Figure: KPS45 & Figure: KPS 47	Permissible overpressure	Max. test pressure	Min. burst pressure	Pressure connection	Code number
	[bar]	[bar]	[bar]	[bar]	[bar]		
KPS 43	1 – 10	0.7 – 2.8	120	180	240	G ¼	060-312066
KPS 45	4 – 40	2.2 – 11	120	180	240	G ¼	060-312166
KPS 47	6 – 60	3.5 – 17	120	180	240	G ¼	060-312266

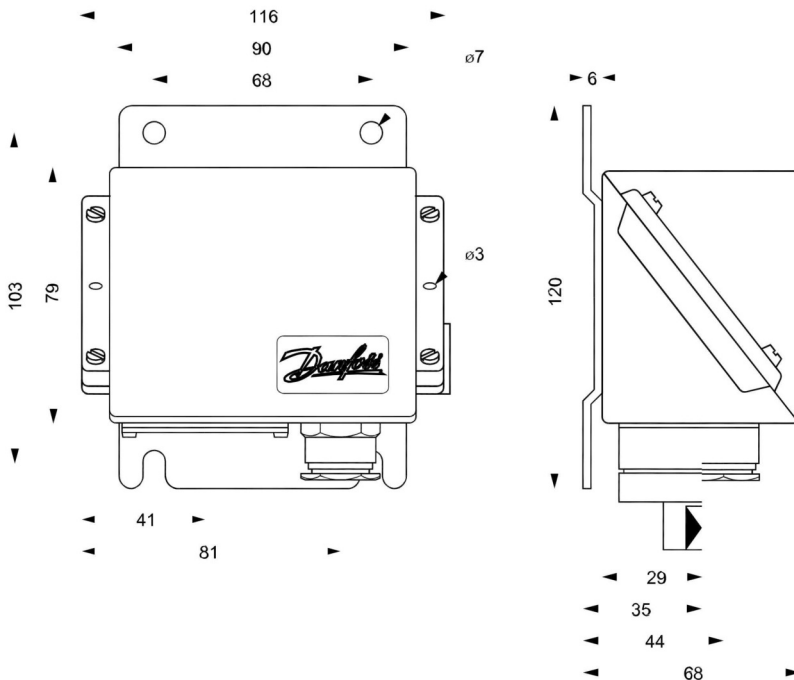
Figure: KPS 43, KPS 45 & 47



NOTE: When ordering, please state type and code number

Dimensions

Figure: KPS



NOTE:

Net weight:

KPS 31 – 39 approx. 1.0 kg

KPS 43 – 47 approx. 1.3 kg

Figure: KPS types

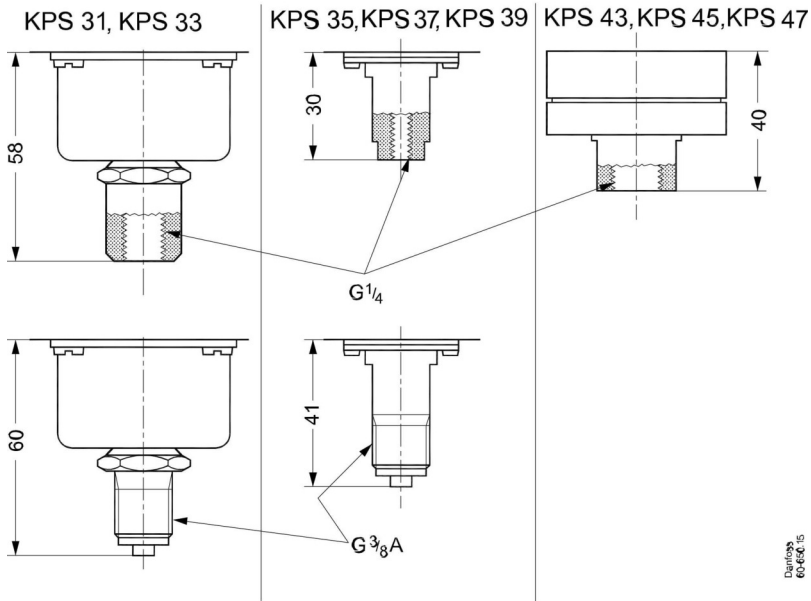
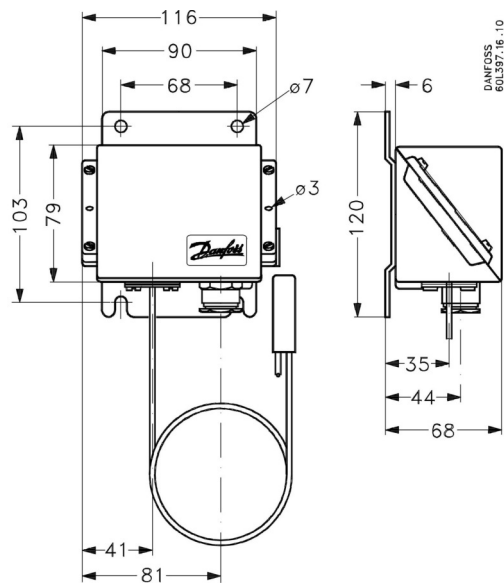
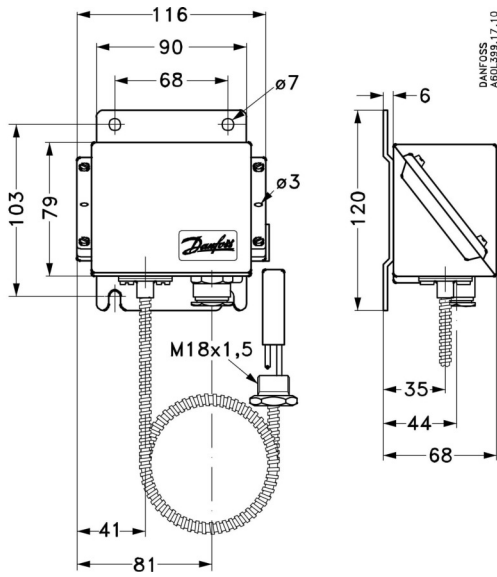


Figure: KPS with remote sensor



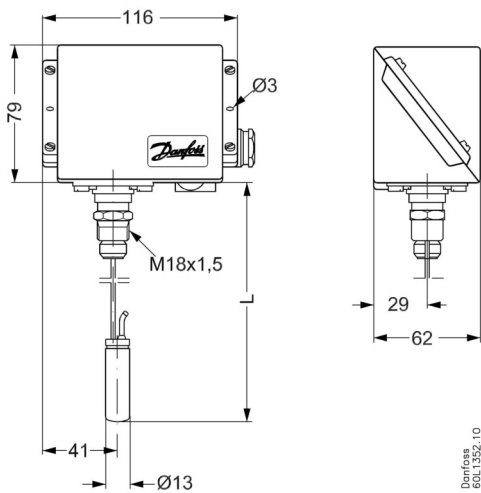
Net weight: ca 1.2 kg (incl. 2 m capillary tube)

Figure: KPS with remote sensor and armored capillary tube



Net weight: ca 1.4 kg (incl. 2 m capillary tube)

Figure: KPS with rigid sensor



Net weight: ca 1.0 kg

Table: Sensor pocket

Sensor pocket length "A"	Sensor length "L"
75	105
110	138
160	190
200	230

Installation

Figure: KPS

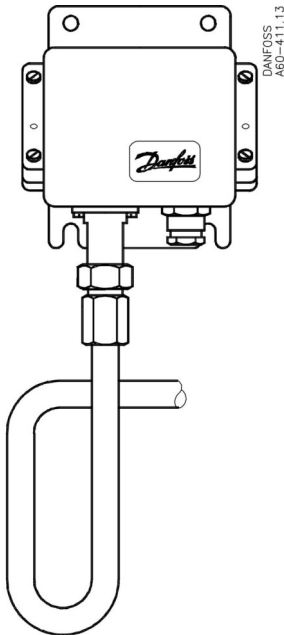
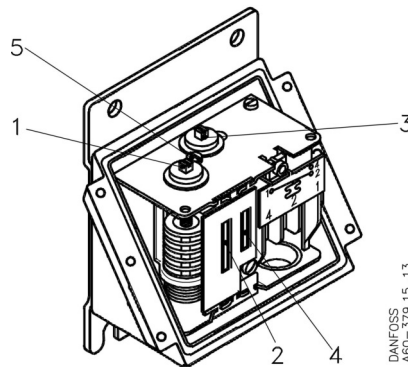


Figure: KPS



1	Range spindle
2	Range scale
3	Differential spindle
4	Differential scale
5	Locking screw

Installation

KPS pressure switches are fitted with a 3 mm steel mounting plate. The units should not be allowed to hang from the pressure connection.

Pressure connection

When fitting or removing pressure lines, the spanner flats on the pressure connection should be used to apply counter-torque.

Steam plant

To protect the pressure element from excessive heat, the insertion of a water-filled loop is recommended. The loop can, for example, be made of 10 mm copper tube.

Water systems

Water in the pressure element is not harmful, but if frost is likely to occur a water-filled pressure element may burst. To prevent this happening, the pressure control can be allowed to operate on an air cushion.

Media-resistance

See [Table: Materials in contact with the medium](#). If seawater is involved, types KPS 43, KPS 45, KPS 47 are recommended.

Pulsations

If the pressure medium is superimposed with severe pulsations, which occur in automatic sprinkler systems (fire protection), fuel systems for diesel motors (priming lines), and hydraulic systems (e.g. propeller systems), etc., types KPS 43, KPS 45, KPS 47 are recommended. The maximum permissible pulsation level for these types is 120 bar.

Setting

When the pressure switch cover is removed, and the locking screw (5) is loosened, the range can be set with the spindle (1) while at the same time the scale (2) is being read. In units having an adjustable differential, the spindle (3) must be used to make the adjustment. The differential obtained can be read direct on the scale (4) or, with types KPS 43, KPS 45, KPS 47, can be determined by reading the scale value and using the nomograms in figs. [I](#). The working line for determining the differential must not intersect the shaded areas in the nomograms.

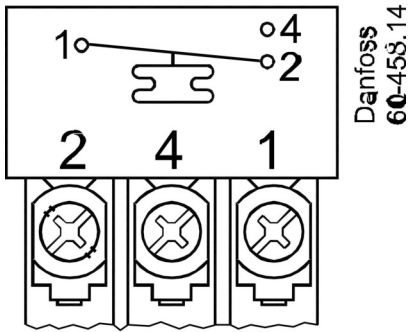
Selection of differential

To ensure that the plant functions properly, a suitable differential pressure is necessary. Too small a differential will give rise to short running periods with a risk of hunting. Too high a differential will result in large pressure oscillations.

Electrical connection

KPS pressure switches are fitted with a Pg 13.5 screwed cable entry that is suitable for cable diameters from 5 – 14 mm. Contact function is shown in [Figure: Contact function](#)

Figure: Contact function



Thermostat

Installation

Location of unit: KPS thermostats are designed to withstand the shocks that occur, e.g. in ships, on compressors and in large machine installations. KPS thermostats with remote sensor are fitted with a base of 3 mm steel plate for fixing to bulkheads, etc. KPS thermostats with bulb sensor are self-supporting from the sensor pocket.

Resistance to media

Material specifications for sensor pockets

Sensor pocket, brass

The tube is made of Ms 72 to DIN 17660, the threaded portion of So Ms 58Pb to DIN 17661.

Sensor pocket, stainless steel

18/8 Material designation 1.4305 to DIN 17440.

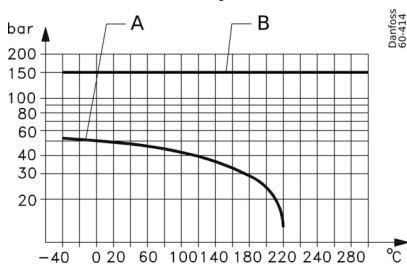
Sensor position

As far as possible the sensor should be positioned so that its longitudinal axis is at right angles to the direction of flow. The active part of the sensor is $\varnothing 13$ mm \times 50 mm long on thermostats with rigid sensors and 2 m capillary tube. The active length on the other thermostats is 70 mm (5 m and 8 m capillary tubes).

The medium

The fastest reaction is obtained from a medium having high specific heat and high thermal conductivity. It is therefore advantageous to use a medium that fulfills these conditions (provided there is a choice). Flow velocity of the medium is also of significance. (The optimum flow velocity for liquids is about 0.3 m/s).

Figure: Permissible media pressure on the sensor pocket as a function of temperature

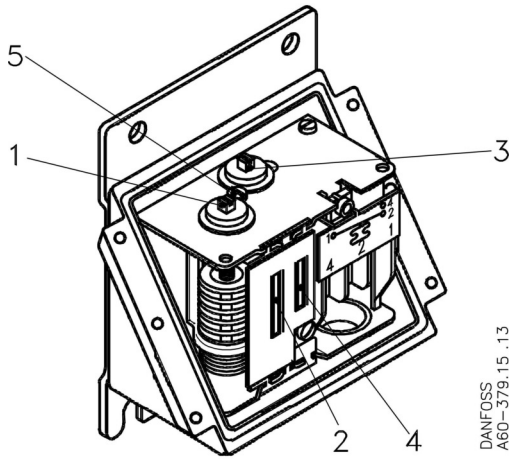


A	Brass
B	Stainless steel

Setting

When the thermostat cover is removed, and the locking screw is loosened, the range can be set with the spindle (1) while at the same time the scale (2) is being read. In units having an adjustable differential, the spindle (3) can be used while the scale (4) is being read.

Figure: KPS



1	Range spindle
2	Range scale
3	Differential spindle
4	Differential scale
5	Locking screw

Scale correction

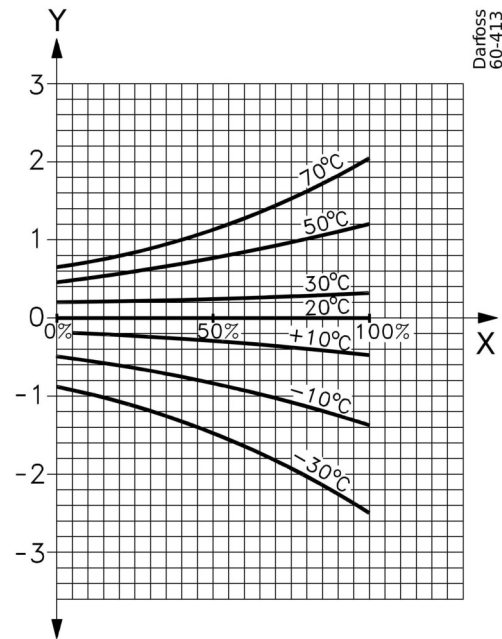
The sensor on KPS thermostats contains an adsorption charge. Therefore function is not affected whether the sensor is placed warmer or colder than the remaining part of the thermostatic element (bellows and capillary tube). However, such a charge is to some extent sensitive to changes in the temperature and bellows and capillary tube. Under normal conditions this is of no importance, but if the temperature control is to be used in extreme ambient temperatures there will be a scale deviation.

The deviation can be compensated for as follows:

$$\text{Scale correction} = Z \times a$$

Z can be found from Figure 22, while a is the correction factor from the table below.

Figure: Scale



Z	Factor for setting point deviation
X	Relative scale setting in [%]

Table: Correction factor for thermostats

Type	Regulation range [°C]	Correction factor for thermostats		
		with rigid sensor	with 2 and 5 m cap. tube	with 8 m cap. tube
KPS 76	-10 – 30	–	1.1	–
KPS 77	20 – 60	1.0	1.4	–
KPS 79	50 – 100	1.5	2.2	2.9
KPS 80	70 – 120	1.7	2.4	3.1
KPS 81	60 – 150	–	3.7	–
KPS 83	100 – 200	–	6.2	–

Example 1

A diesel engine with cooling water temperature of 85 °C (normal). An alarm must be triggered if the cooling water temperature exceeds 95 °C. Choose a KPS 80 thermostat (range 70 – 120 °C). Main spindle setting: 95 °C. Differential spindle setting: 5 °C. The required alarm function is obtained by connecting to thermostat terminals 1–4. After the system has been in operation, assess the operating differential and make a correction if necessary.

Example 2

Find the necessary scale correction for a KPS 80 set at 95 °C in 50 °C ambient temperature. The relative scale setting Z can be calculated from the following formula:

$$\frac{\text{Setting value} - \text{min. scale value}}{\text{max. scale value} - \text{min. scale value}} \times 100 = \%$$

Relative scale setting: $\frac{95-70}{120-70} \times 100 = 50\%$

Factor for scale deviation, $Z \approx 0.7$

Correction factor a ([Table: Correction factor for thermostats](#)) = 2.4

Scale correction = $Z \times a = 0.7 \times 2.4 = 1.7$ °C

The KPS must be set at $95 + 1.7 = 96.7$ °C

Certificates, declarations and approvals

The list contains all certificates, declarations, and approvals for this product type. Individual code number may have some or all of these approvals, and certain local approvals may not appear on the list.

When you click on the link you will be directed to the latest version of the 'Declaration of Conformity'. Products developed and sold before this date of issue conform to the directives/standards in force at the time of their sale.

Approval type	Title	Certification body	Approval topic
Electrical Safety Certificate	EAC KZ 7100841.01.01.01391	EAC - Eurasian Customs Union	EMC
UA Declaration	Danfoss UA 2024-07-25 cooling sensors	Danfoss	EMC, LVD
UA Declaration	Danfoss UA 2023-01-10 Regulators PL01 PL04	Danfoss	PED, Pressure
Manufacturer's Declaration	Danfoss MD 060-9639.AB	Danfoss	China RoHS
EU Declaration	Danfoss EU 060-9680.AC	Danfoss	LVD
Marine Certificate	BV 04958-H0 BV	BV - Bureau Veritas	Marine
Marine Certificate	DNV TAA000026C Rev.01	DNV GL	Marine
Marine Certificate	CCS GB23PTB00006 01	CCS - China Classification Society	Marine
Marine Certificate	KR HMB 17529-AE003	KR - Korean Register of Shipping	Marine
Pressure Safety Certificate	LLC CDC EURO-TYSK UA.TR.089.1015.05-22	LLC CDC EURO TYSK - Ukraine	Pressure
CCC Declaration	Danfoss CCC 2024010305641305	Danfoss	CCC
Marine Certificate	NKK TA24044M	ClassNK - The Japanese Marine Association	
Marine Certificate	ABS 25-0336468-PDA	ABS - American Bureau of Shipping	
Electrical Safety Certificate	UL E73170	UL - Underwriters Laboratories inc.	
CCC Declaration	Danfoss CCC 2020970305003454	Danfoss	
Marine Certificate	LR21358064TA	LR - Lloyd's Register	
Marine Certificate	RINA ELE282125XG	RINA - Registro Italiano Navale	
Export Control Declaration	Pressure switches & Thermostats	Danfoss	
Marine Certificate	BV 04266 IO BV	BV - Bureau Veritas	

Contact details

Online support

Danfoss offers a wide range of support along with our products, including digital information, software, mobile apps and expert guidance. See the possibilities below.



The Danfoss Design center

Discover the Design Center, our advanced digital platform that streamlines product selection. With integrated tools and enhanced type pages, it's simpler than ever to access product information and documentation, and to select the right products. Check the availability of Danfoss products at partner locations and enjoy seamless transitions from selection to purchase with our basket-to-basket functionality. Whether you're buying from our distributors or directly from the Product Store, the Design Center simplifies your experience. Learn more at: designcenter.danfoss.com.



The Danfoss product store

The Danfoss Product Store is a one-stop shop available 24/7 for our customers, no matter where you are in the world or what area of industry you work in. Browse our catalog, check product details and documentation, view your prices and product availability, and quickly finalize your purchase. Start browsing at: store.danfoss.com.



Danfoss Partner Portal/Product Data tool

Designed to support you with easy access to product data extracts, essential resources, tools, and information. The Partner Portal provides a centralized hub for product documentation, training materials, marketing assets, and technical support, ensuring you have everything you need to succeed and grow your business with Danfoss. The Partner Portal is available 24/7 at: partner.danfoss.com and is ready to support your business.



Find technical documentation

Find technical documentation you need to get your project up running. Get direct access to our official collection of data sheets, certificates and declarations, manuals and guides, 3D models and drawings, case stories, brochures, and much more. Start searching now at: documentation.danfoss.com.



Danfoss Learning

Danfoss Learning is a free online learning platform. It features courses and materials specifically designed to help engineers, installers, service technicians, and wholesalers better understand the products, applications industry topics, and trends that will help you do your job better. Find your local Danfoss website here: learning.danfoss.com.



Get local information and support

Local Danfoss websites are the main sources for help and information about our company and products. Find product availability, get the latest regional news, or connect with a nearby expert - all in your own language. Find your local Danfoss website here: danfoss.com.

Danfoss A/S

Climate Solutions . danfoss.com . +45 7488 2222

Any information, including, but not limited to information on selection of product, its application or use, product design, weight, dimensions, capacity or any other technical data in product manuals, catalogues description, advertisements, etc. and whether made available in writing, orally, electronically, online or via download, shall be considered informative, and is only binding if and to the extent, explicit reference is made in a quotation or order confirmation. Danfoss cannot accept any responsibility for possible errors in catalogues, brochures, videos and other material. Danfoss reserves the right to alter its products without notice. This also applies to products ordered but not delivered provided that such alterations can be made without changes to form, fit or function of the products. All trademarks in this material are property of Danfoss A/S or Danfoss group companies. Danfoss and the Danfoss logo are trademarks of Danfoss A/S. All rights reserved.
